



Boise Cascade®

**LIMIT STATES DESIGN
CANADA**



INSTALLATION GUIDE

**ALLJoist®
BCI® Joist
Versa-Lam®**

The information in this document pertains to use in **CANADA ONLY**, Limit States Design. Refer to the Specifier Guide in each region for use in the United States.

CANADA INSTALL GUIDE ENGLISH VERSION 09/23/2019

Product Profiles

ALLJoist® Product Profiles

AJS® 140

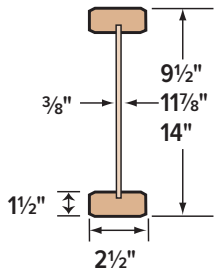

AJS® 20

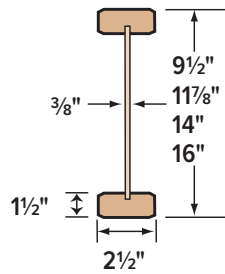

AJS® 25

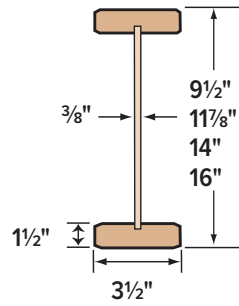

AJS® 25
Deeper Depths

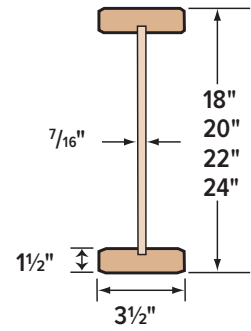

BCI® Product Profiles

BCI® 4500s

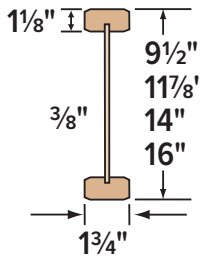

BCI® 5000
BCI® 5000s

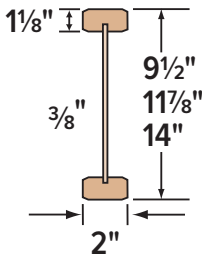

BCI® 6000
BCI® 6000s

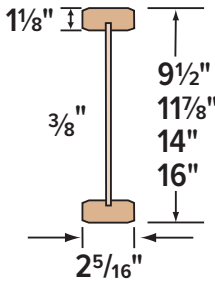

BCI® 6500
BCI® 6500s

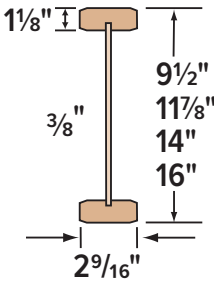

BCI® 60
BCI® 60s

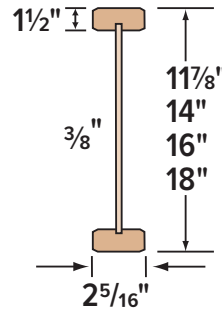

BCI® 90
BCI® 90s

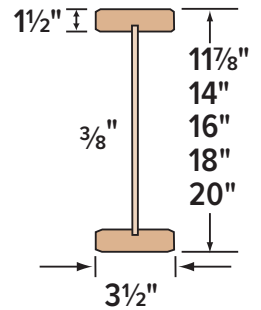

Versa-Lam®, Versa-Stud® and BOISE CASCADE® Rimboard Product Profiles

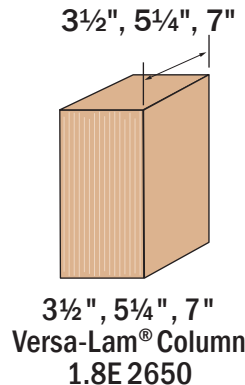
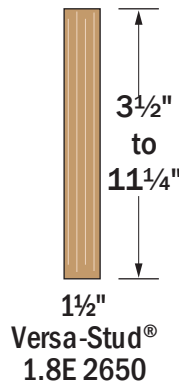
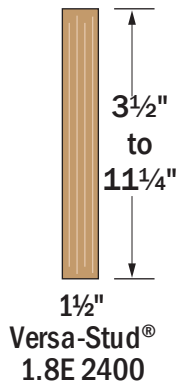
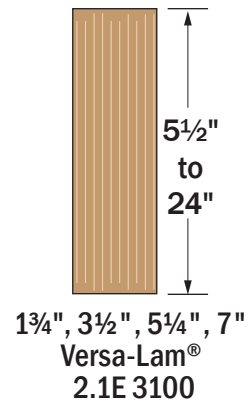
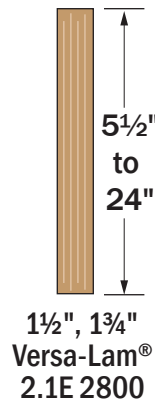
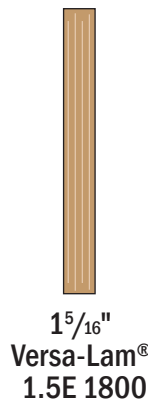
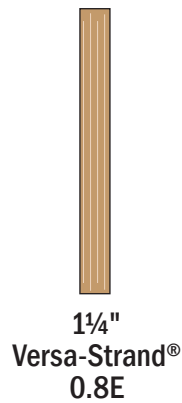

Products may not be available in all regions, please contact your local distributor for availability

NOTE

The illustration below is showing several suggested applications for the Boise Cascade EWP products. It is not intended to show an actual house under construction.

NO MIDSPAN BRIDGING IS REQUIRED FOR AJS®/BCI® JOIST.

FOR INSTALLATION STABILITY, Temporary strut lines (1x4 min.) 8' on center max. Fasten at each joist with 2-2½" (8d) nails minimum.

Dimension lumber is not suitable for use as a rim board in AJS®/BCI® floor systems.

AJS®/BCI® blocking or 2x4 "squash" block on each side required when supporting a load-bearing wall above.

When installing Boise Cascade EWP products with treated wood, use only connectors/fasteners that are approved for use with the corresponding wood treatment.

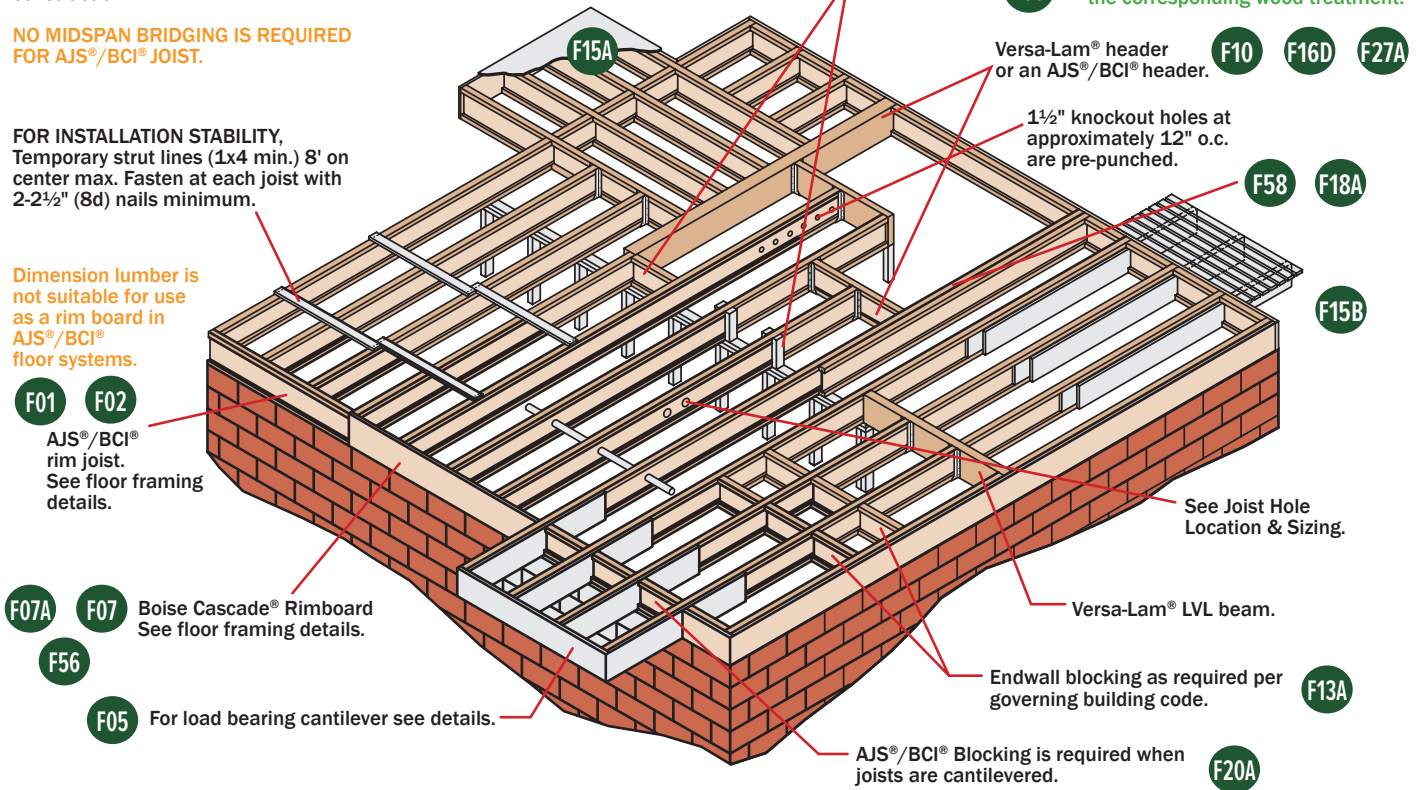

AJS®/BCI® Joists – Floor Framing Details

<p>F01</p> <p>AJS®/BCI® blocking</p>	<p>F02</p> <p>AJS®/BCI® rim joist</p> <p>2x6 wall for minimum bearing, joist with flange of 3½" width only.</p>	<p>F03</p> <p>AJS®/BCI® rim joist</p> <p>2x6 wall for minimum bearing, joist with flange of 3½" width only.</p> <p>Note: AJS®/BCI® floor joist must be designed to carry wall above when not stacked over wall below.</p>
<p>F07</p> <p>Boise Cascade® Rimboard</p> <p>Nail Boise Cascade® Rimboard to AJS®/BCI® Joists with 2½" (8d) nail into each flange.</p> <p>Dimension lumber is not suitable for use as rim board with AJS®/BCI® Joists.</p>	<p>F07A</p> <p>Boise Cascade® Rimboard</p> <p>Dimension lumber is not suitable for use as rim board with AJS®/BCI® Joists.</p>	<p>F13A</p> <p>AJS®/BCI® joist blocking as required by governing building code.</p>

F06

For load bearing wall above (stacked over wall below).

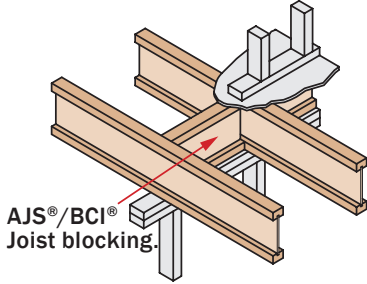

AJS®/BCI® Joist blocking.

F09

Blocking may be required, consult design professional of record and/or local building official.

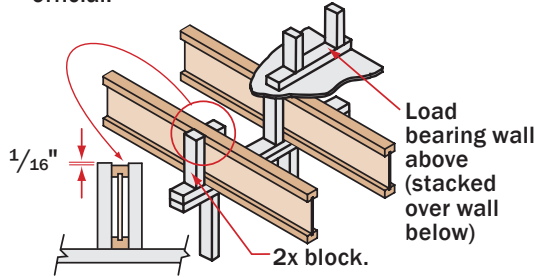

Nail block with one 3" (10d) nail into each flange.

Double Squash Block Vertical Load [lb/ft]				
Size	Joist Spacing [in]			
	12	16	19.2	24
2x4	6460	4840	4030	3230
2x6	10140	7600	6330	5070

1. Squash blocks are to be in full contact with upper floor and lower wall plate.
2. Capacities shown are for a double squash blocks at each joist, SPF or better.

F08

Solid block all posts from above to bearing below.

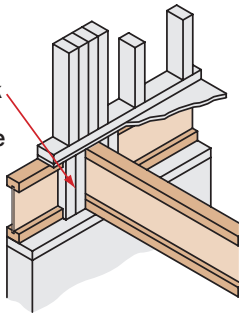

F31

Ledger for sheathing nailing may be required per governing code

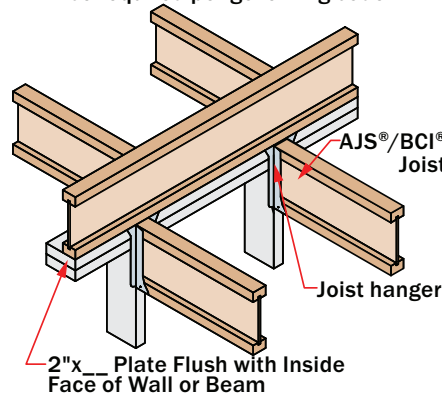

2"x__ Plate Flush with Inside Face of Wall or Beam

F38

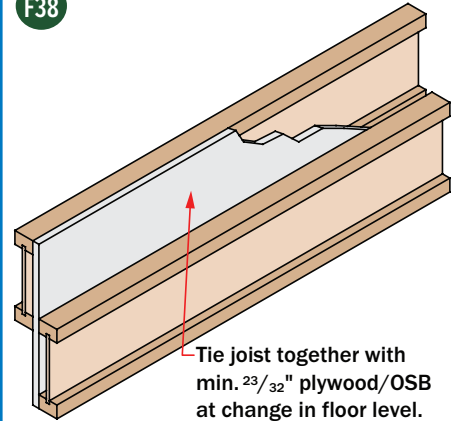

Tie joist together with min. 23/32" plywood/OSB at change in floor level.

F18A

Backer Blocks

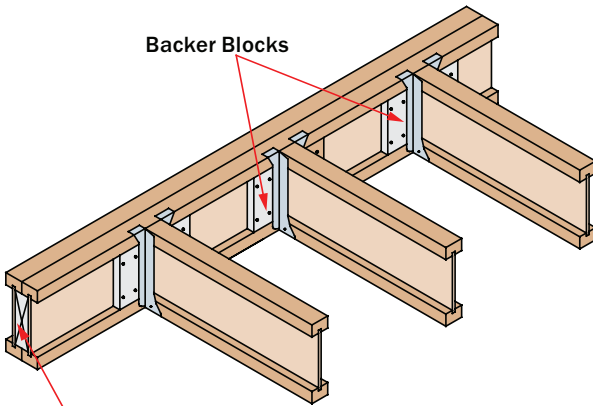

Filler blocking required for the entire length.

F58

Filler Block (if required) See TN IJ-13 for requirements.

Web Filler Nailing See TN IJ-13 for joist specific schedule.

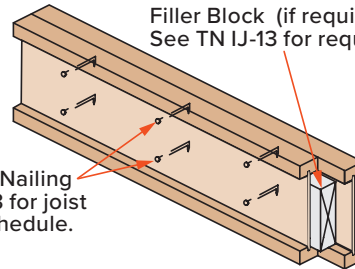

- Filler block not required when all loads are top loaded and evenly applied to each ply (except BCI® 90 and AJS® 25, 30). Side loads and/or uneven top loads require filler block.
- See Boise Cascade Technical Note IJ-13 for further information.
- Fasten floor sheathing to each ply per diaphragm nailing schedule.

F10

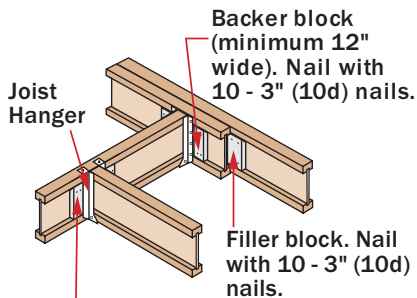

Backer block required where top flange joist hanger load exceeds 250 lbs. Install tight to top flange.

F16D

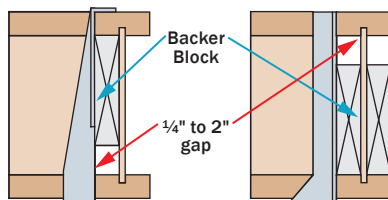

"Top Mount" Backer block shall be tight to bottom of top flange with 1/4" to 2" gap at top of bottom flange.

"Face Mount" Backer block shall be tight to top of bottom flange with 1/4" to 2" gap at bottom of top flange.

Hanger Connections to AJS®/BCI® Headers

- Backer blocks shall be at least 12" long per hanger.
- Nails shall be clinched when possible.
- Verify capacity and fastening requirements of hangers and connectors.

F16C

Web stiffeners are not required when top flange is laterally supported by joist hanger.

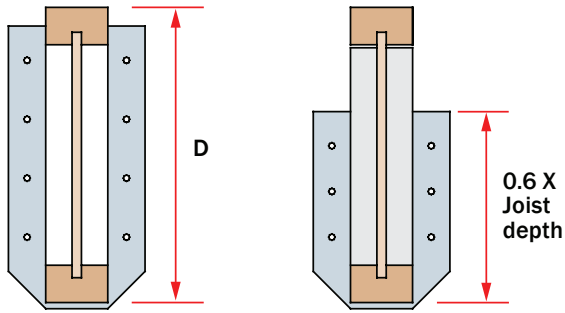

F52

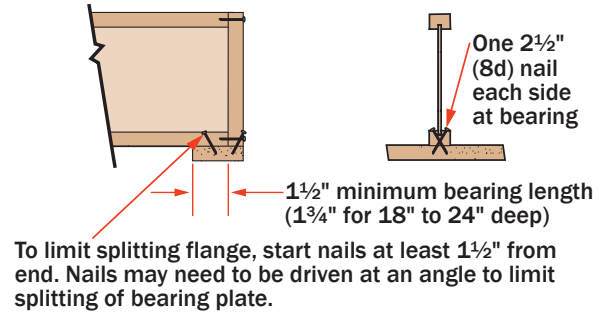

F56

1/2" dia through bolts (ASTM A307 Grades A&B, SAE J429 Grades 1 or 2, or higher) with washers and nuts or 1/2" dia lag screws (full penetration)
585 lbs capacity for 1 1/8" & thicker rim, 500 lbs capacity for 1" rim, per fastener.

Treated Ledger
Use only fasteners that are approved for use with corresponding wood treatment.

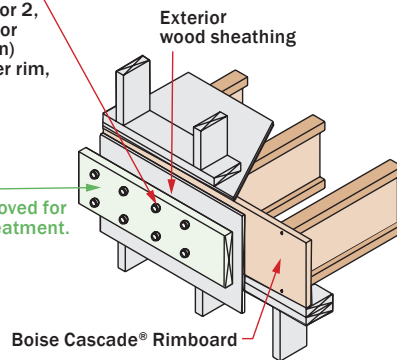

Design of moisture control by others (only structural components shown above)

F15D

Connection on Steel Beam

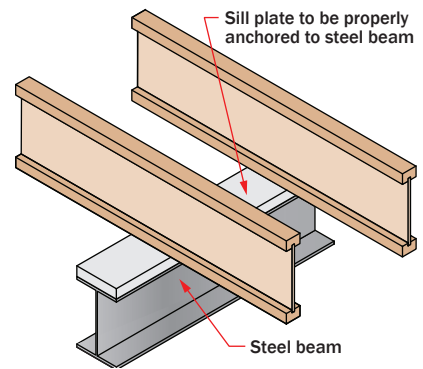

F15E

Connection with Hanger on Steel Beam

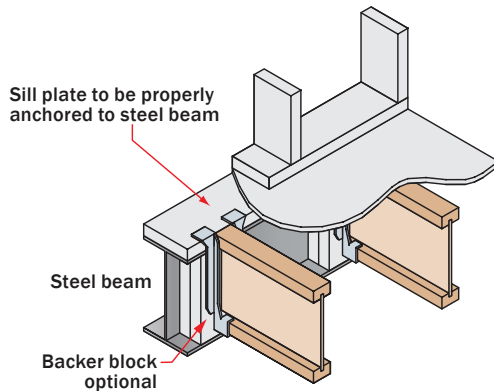

F15C

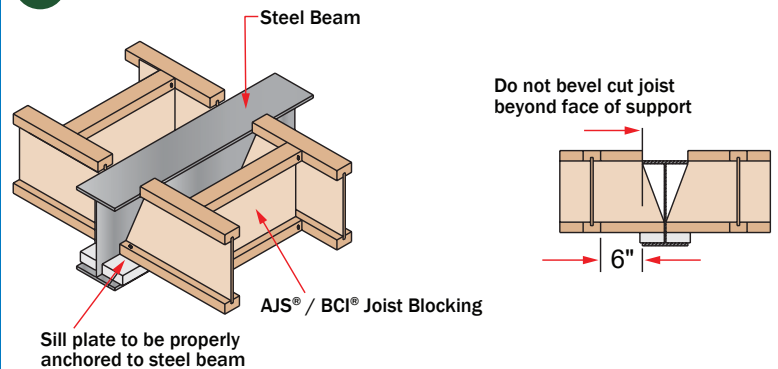

F27A

Top Flange or Face Mount Joist Hanger

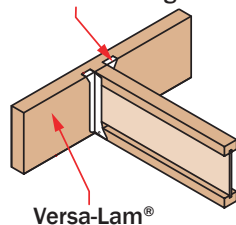

OJ

Offset Joist for Plumbing

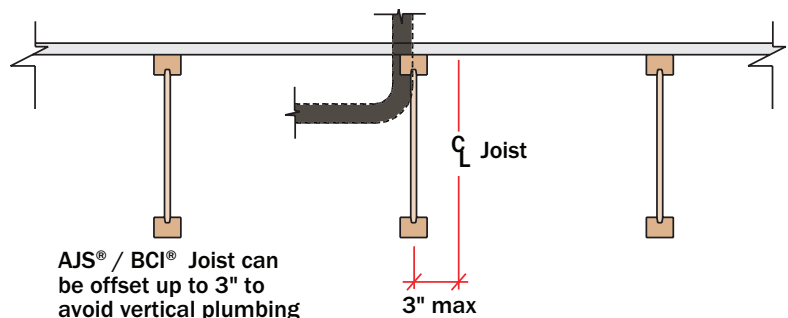

LATERAL SUPPORT

- Joists must be laterally supported at the ends with hangers, rim joists, rim boards, blocking panels or x-bracing. Blocking panels or x-bracing are required at cantilever supports.
- Blocking may be required at intermediate bearings for floor diaphragm as per Code, consult local building official.

MINIMUM BEARING LENGTH FOR AJS®/BCI® JOISTS

- AJS® Joist: 1½ inches is required at end supports (1¼ inches for 18" to 24" deep). 3½ inches is required at cantilever and intermediate supports.
- BCI® Joist: Minimum bearing length at end support is 1½ inches. 3½ inches is required at cantilever and intermediate supports.
- Longer bearing lengths allow higher reaction values. Refer to the building code evaluation report or the BC Calc® software.

NAILING REQUIREMENTS

- AJS®/BCI® rim joist, rim board or closure panel to AJS®/BCI® Joist:
 - Rims or closure panel 1¼ inches thick and less: 2-2½" (8d) nails, one each in the top and bottom flange.
 - AJS® 140/20 rim joist: 2-3½" (16d) box nails, one each in the top and bottom flange.
 - AJS® 25 rim joist: Toe-nail top flange to rim joist with 2-3" (10d) box nails, one each side of flange
 - BCI® 4500s, 5000, 5000s rim joist: 2-3" (10d) box nails, one each in the top and bottom flange.
 - BCI® 6000, 6000s, 60, 60s rim joist: 2-3½" (16d) box nails, one each in the top and bottom flange.
 - BCI® 6500, 6500s, 90, 90s rim joist: Toe-nail top flange to rim joist with 2-3" (10d) box nails, one each side of flange.
- AJS®/BCI® rim joist, rim board or AJS®/BCI® blocking panel to support:
 - 2½" (8d) nails at 6 inches on center.
 - When used for shear transfer, follow the building designer's specification.
- AJS®/BCI® Joist to support:
 - 2-2½" (8d) nails, one on each side of the web, placed 1½ inches minimum from the end of the AJS®/BCI® Joist to limit splitting.
- Sheathing to AJS®/BCI® Joist:
 - Prescriptive residential roof sheathing nailing requires 2½" (8d) common nails @ 6" o.c. on edges and @ 12" o.c. in the field as per Code.
 - Maximum nail spacing for minimum lateral stability = 24".
 - BCI® 4500s, 5000, 5000s joist: Maximum nail spacing is 18 inches on center.
 - 14 gauge staples may be substituted for 2½" (8d) nails if the staples penetrate at least 1 inch into the joist.
 - Wood screws may be acceptable, contact local building official and (or) Boise Cascade EWP Engineering for further information.

WEB STIFFENER REQUIREMENTS

- See *Web Stiffener details*.

AJS® RIM JOISTS AND BLOCKING

AJS® Joist Depth	Vertical Load Transfer Capacity (plf)
9½"	2950
11⅞"	2650
14"	2350
16"	2100
18" - 20"	5100 ⁽¹⁾
22" - 24"	4250 ⁽¹⁾

- (1) Web stiffeners required at each end of blocking panel. Distance between stiffeners must be less than 24".

BCI® RIM JOISTS AND BLOCKING

Depth [in]	BCI® Joist Series	Vertical Load Resistance	
		No W.S. ⁽¹⁾	W.S. ⁽²⁾
9½"	5000 1.7, 6000 1.8, 6500 1.8 4500s 1.8, 5000s 1.8, 6000s 1.8, 6500s 1.8	2900	N/A
11⅞"	5000 1.7, 6000 1.8, 6500 1.8 4500s 1.8, 5000s 1.8, 6000s 1.8, 6500s 1.8	2700	N/A
	60 2.0, 90 2.0 60s 2.0, 90s 2.0	3150	N/A
14"	5000 1.7, 6000 1.8, 6500 1.8 4500s 1.8, 5000s 1.8, 6000s 1.8, 6500s 1.8	2500	N/A
	60 2.0, 90 2.0 60s 2.0, 90s 2.0	3050	N/A
16"	6000 1.8, 6500 1.8 6000s 1.8, 6500s 1.8	2400	3150
	60 2.0, 90 2.0 60s 2.0, 90s 2.0	2900	3400
18"	60 2.0, 90 2.0 60s 2.0, 90s 2.0	N/A	3400
20"	90 2.0 90s 2.0	N/A	3400

(1) No web stiffeners required

(2) Web stiffeners required at each end of blocking, values not applicable for rim joists

N/A: Not applicable

BACKER AND FILLER BLOCK DIMENSIONS

Series	Backer Block Thickness	Filler Block Thickness
AJS® 140	1⅞" or two ½" wood panels	2 x ___ + ⅝" wood panel
AJS® 20	1⅞" or two ½" wood panels	2 x ___ + ⅝" wood panel
AJS® 25	2 x _ lumber	Double 2 x ___ lumber
4500s 1.8	⅝" wood panel	One ⅝" or ¾" wood panel
5000 1.7 5000s 1.8	¾" or ⅞" wood panels	Two ¾" wood panels or 2 x _
6000 1.8 6000s 1.8	1⅞" or two ½" wood panels	2 x _ + ⅝" or ¾" wood panel
6500 1.8 6500s 1.8	1⅞" or two ½" wood panels	2 x _ + ⅝" or ¾" wood panel
60 2.0 60s 2.0	1⅞" or two ½" wood panels	2 x _ + ⅝" or ¾" wood panel
90 2.0 90s 2.0	2 x _ lumber	Double 2 x _ lumber

- Cut backer and filler blocks to a maximum depth equal to the web depth minus ¼" to avoid a forced fit.
- For 18" and deeper Joists, stack 2x lumber or use multiple pieces of ¾" wood panels.

PROTECT AJS®/BCI® JOISTS FROM THE WEATHER

- AJS®/BCI® Joists is intended only for applications that provide permanent protection from the weather. Bundles of product should be covered and stored off of the ground on stickers.

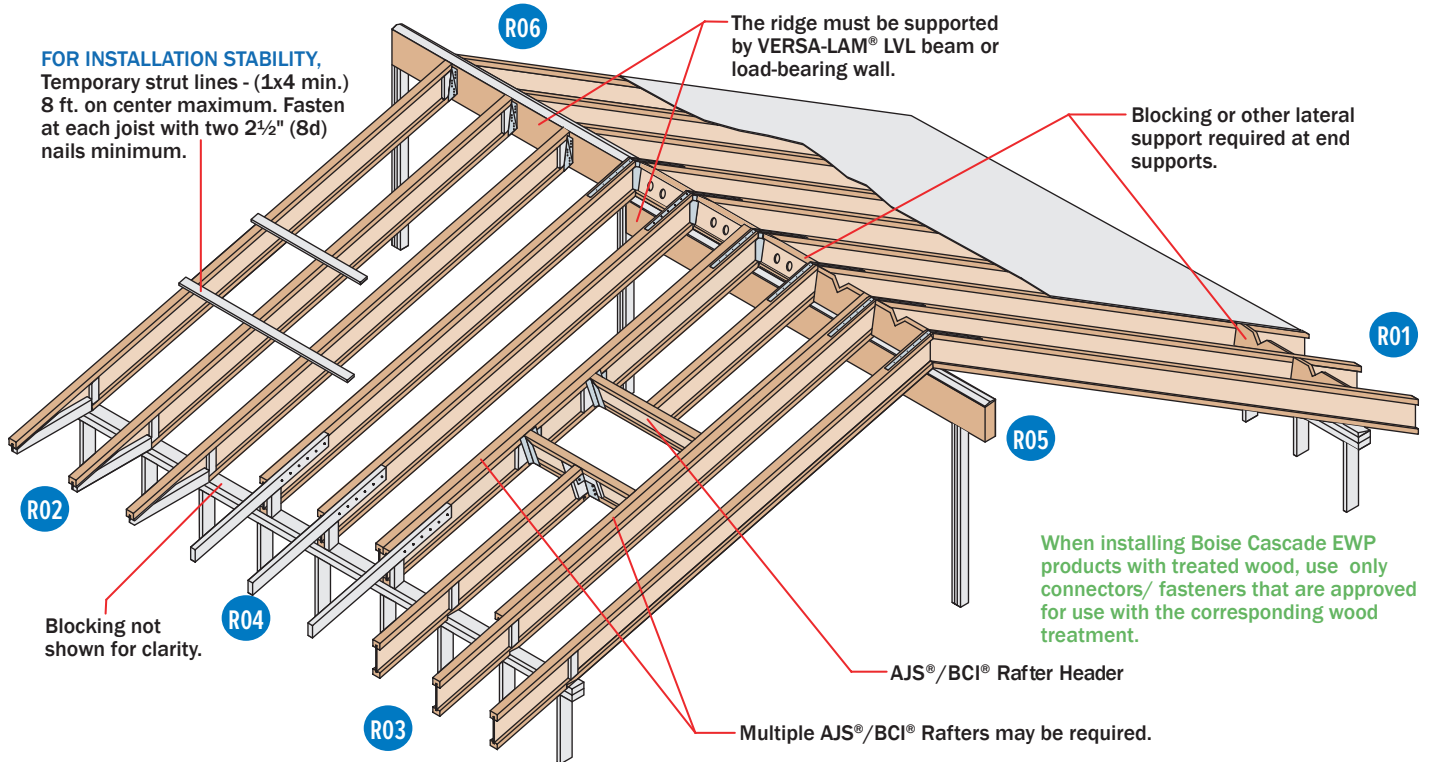

AJS®/BCI® Joists — Roof Framing Details

<p>R01</p> <p>2x beveled plate for slope greater than ¼/12.</p> <p>Simpson VPA or USP TMP connectors or equal can be used in lieu of beveled plate for slopes from 3/12 to 12/12.</p>	<p>R02</p> <p>Rimboard / Versa-Lam® blocking. Ventilation "V" cut: ⅓ of length, ½ of depth</p> <p>2x4 blocking for soffit support. 2'-6" max.</p> <p>Flange of AJS®/BCI® Joists may be birdsmouth cut only at the low end of the joist. Birds mouth cut AJS®/BCI® joist must bear fully on plate, web stiffener required each side. Bottom flange shall be fully supported.</p>	<p>R04</p> <p>3" (10d) nails at 6" o.c.</p> <p>2x4 one side for 135 PLF max. 2x6 one side for 240 PLF max.</p> <p>Backer block. Thickness per corresponding AJS®/BCI® series.</p> <p>2x block AJS®/BCI® blocking. Holes cut for ventilation.</p> <p>4'-0" horiz. 2'-6" horiz.</p>
<p>R05</p> <p>Simpson or USP LSTA24 strap, nailing per governing building code.</p> <p>Versa-Lam® LVL support beam.</p> <p>AJS®/BCI® blocking. Holes cut for ventilation.</p> <p>Double-beveled wood plate.</p> <p>Blocking on both sides of ridge may be required for shear transfer per design professional of record.</p>	<p>R06</p> <p>Simpson or USP LSTA24 strap where slope exceeds 7/12 (straps may be required for lower slopes in high-wind areas). Nailing per governing building code.</p> <p>Versa-Lam® LVL support beam.</p> <p>Beveled web stiffener on each side.</p> <p>Simpson LSSUI or USP TMU hanger.</p>	<p>R11</p> <p>Double joist may be required when L exceeds rafter spacing.</p> <p>Blocking as required.</p> <p>Nail outrigger through BCI® web.</p> <p>2" x outrigger notched around BCI® top flange. Outrigger spacing no greater than 24" on-center.</p> <p>End Wall.</p> <p>L (2'-0" max.)</p>
<p>R03</p> <p>Rimboard / Versa-Lam® blocking. Ventilation "V" cut: ⅓ of length, ½ of depth</p> <p>Tight fit for lateral stability.</p> <p>2'-6" max.</p> <p>Flange of AJS®/BCI® Joists may be birdsmouth cut only at the low end of the joist. Birds mouth cut AJS®/BCI® Joist must bear fully on plate, web stiffener required each side.</p>	<p>DN05</p> <p>DO NOT bevel-cut joist beyond inside face of wall, except for specific conditions in details shown on pages 6 and 13 of the Eastern Specifier Guide.</p>	

LATERAL SUPPORT

- Joists must be laterally supported at the ends with hangers, rim joists, rim boards, blocking panels or x-bracing. Blocking panels or x-bracing are required at cantilever supports. Metal cross bracing or other x-bracing provides adequate lateral support for BCI® Joists, consult governing building code for roof diaphragm connection provisions.

MINIMUM BEARING LENGTH FOR AJS®/BCI® JOISTS

- AJS® Joist: 1½ inches is required at end supports (1¾ inches for 18" to 24" deep). 3½ inches is required at cantilever and intermediate supports.
- BCI® Joist: Minimum bearing length at end support is 1½ inches. 3½ inches is required at cantilever and intermediate supports.
- Longer bearing lengths allow higher reaction values. Refer to the building code evaluation report or the BC CALC® software.

NAILING REQUIREMENTS

- AJS®/BCI® rim joist, rim board or closure panel to AJS®/BCI® Joist:
 - Rims or closure panel 1¾ inches thick and less: 2- 2½" (8d) nails, one each in the top and bottom flange.
 - AJS® 140 / 20 rim joist: 2- 3½" (16d) box nails, one each in the top and bottom flange.
 - AJS® 25 rim joist: Toe-nail top flange to rim joist with 2-3" (10d) box nails, one each side of flange.
 - BCI® 4500s, 5000, 5000s rim joist: 2-3" (10d) box nails, one each in the top and bottom flange.
 - BCI® 6000, 6000s, 60, 60s rim joist: 2-3½" (16d) box nails, one each in the top and bottom flange.
 - BCI® 6500, 6500s, 90, 90s rim joist: Toe-nail top flange to rim joist with 2-3" (10d) box nails, one each side of flange.
- AJS®/BCI® rim joist, rim board or AJS®/BCI® blocking panel to support:
 - 2½" (8d) nails at 6 inches on center.
 - When used for shear transfer, follow the building designer's specification.
- AJS®/BCI® Joist to support:
 - 2- 2½" (8d) nails, one on each side of the web, placed 1½ inches minimum from the end of the AJS®/BCI® Joist to limit splitting.
- Sheathing to AJS®/BCI® Joist:
 - Prescriptive residential roof sheathing nailing requires 2½" (8d) common nails @ 6" o.c. on edges and @ 12" o.c. in the field as per Code.
 - Maximum nail spacing for minimum lateral stability = 24".
 - BCI® 4500s, 5000, 5000s joist: Maximum nail spacing is 18 inches on center.
 - 14 gauge staples may be substituted for 2½" (8d) nails if the staples penetrate at least 1 inch into the joist.
 - Wood screws may be acceptable, contact local building official and/or Boise Cascade EWP Engineering for further information.

BACKER AND FILLER BLOCK DIMENSIONS

Series	Backer Block Thickness	Filler Block Thickness
AJS® 140	1½" or two ½" wood panels	2 x ___ + ⅝" wood panel
AJS® 20	1½" or two ½" wood panels	2 x ___ + ⅝" wood panel
AJS® 25	2 x _ lumber	Double 2 x ___ lumber
4500s 1.8	⅝" wood panel	One ⅝" or ¾" wood panel
5000 1.7 5000s 1.8	¾" or ⅞" wood panels	Two ¾" wood panels or 2 x _
6000 1.8 6000s 1.8	1½" or two ½" wood panels	2 x _ + ⅝" or ¾" wood panel
6500 1.8 6500s 1.8	1½" or two ½" wood panels	2 x _ + ⅝" or ¾" wood panel
60 2.0 60s 2.0	1½" or two ½" wood panels	2 x _ + ⅝" or ¾" wood panel
90 2.0 90s 2.0	2 x _ lumber	Double 2 x _ lumber

- Cut backer and filler blocks to a maximum depth equal to the web depth minus ¼" to avoid a forced fit.
- For 18" and deeper Joist, stack 2x lumber or use multiple pieces of ¾" wood panels.

WEB STIFFENER REQUIREMENTS

- See *Web Stiffener Requirements* see details.

MAXIMUM SLOPE

- Unless otherwise noted, all roof details are valid for slopes of 12 in 12 or less.

VENTILATION

- The 1½ inch, pre-stamped knock-out holes spaced at 12 inches on center along the AJS®/BCI® Joist may all be knocked out and used for cross ventilation. Deeper joists than what is structurally needed may be advantageous in ventilation design. Consult local building official and/or ventilation specialist for specific ventilation requirements.

BIRDSMOUTH CUTS

- AJS®/BCI® Joists may be birdsmouth cut only at the low end support. AJS®/BCI® Joists with birdsmouth cuts may cantilever up to 2'-6" past the low end support. The bottom flange must sit fully on the support and may not overhang the inside face of the support. High end supports and intermediate supports may not be birdsmouth cut.

PROTECT AJS®/BCI® JOISTS FROM THE WEATHER

- AJS®/BCI® Joists are intended only for applications that provide permanent protection from the weather. Bundles of AJS®/BCI® Joists should be covered and stored off of the ground on stickers.

AJS® / BCI® Ceiling Joist with Bevel End Cut (For Limited-Access Attics Only)

AJS®/BCI® Joist shall not be used as collar/tension tie. Roof rafter shall be supported by ridge beam or other upper bearing support.

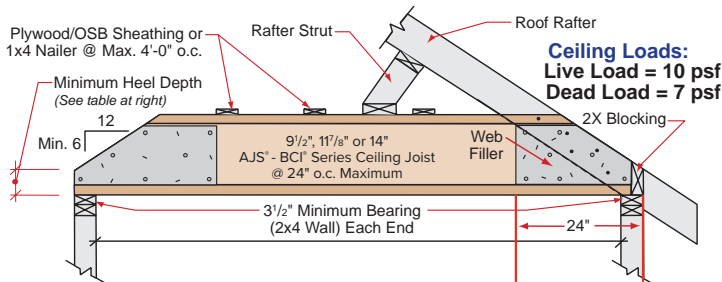

Notes:

- Detail is to be used only for ceiling joists with no access to attic space.
- Ceiling joist must be designed to carry all roof load transferred through rafter struts as shown.
- AJS®/BCI® ceiling joist end reaction may not exceed 550 pounds.
- Minimum roof slope is 6/12.
- Nail roof rafter to AJS®/BCI® top flange with 1-3" (12d) box or larger nail.
- 1x4 nailers must be continuous and nailed to a braced end wall.
- Install a web filler on each side of AJS®/BCI® Joist at beveled ends. Nail roof rafter to AJS®/BCI® Joist per building code requirements for ceiling joist to roof rafter connection.

Maximum Span Lengths Without Roof Loads		
9½"	AJS® 140 / 20 / 25 BCI® 5000 1.7 / 6000 1.8 / 6500 1.8 BCI® 4500s 1.8 / 5000s 1.8 / 6000s 1.8 / 6500s 1.8	19'-6"
11⅞"	AJS® 140 / 20 / 25 BCI® 5000 1.7 / 6000 1.8 / 6500 1.8 BCI® 4500s 1.8 / 5000s 1.8 / 6000s 1.8 / 6500s 1.8	22'-0"
14"	AJS® 140 / 20 / 25 BCI® 6000 1.8 / 6500 1.8 BCI® 4500s 1.8 / 5000s 1.8 / 6000s 1.8 / 6500s 1.8	25'-0"

(If roof loads present, see Notes 2 & 3 below)

Minimum Heel Depths	Joist Depth	End Wall	
		2 x 4	2 x 6
9½"	9½"	2½"	1½"
	11⅞"	3½"	2½"
	14"	4½"	3½"

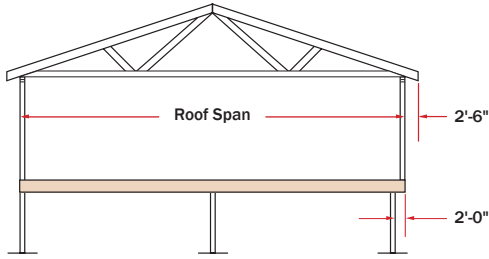

The tables and details shown in the product Specifiers Guides indicate the type of reinforcements, if any, that are required for load-bearing cantilevers up to a maximum length of 2'-0". Cantilevers longer than 2'-0" cannot be reinforced. **However, longer cantilevers with lower loads may be allowable without reinforcement. Analyze specific applications with the BC Calc® software.**

PLYWOOD / OSB REINFORCEMENT (If Required per Load Bearing Cantilever Tables in Product Specifiers Guides)

- $2\frac{3}{32}$ " Min. x 48" long plywood / OSB rated sheathing must match the full depth of the Joist. Nail to the Joist with $2\frac{1}{2}$ " (8d) nails at 6" o.c. and nail with $4\text{-}2\frac{1}{2}$ " (8d) nails into backer block. When reinforcing both sides, stagger nails to limit splitting. Install with horizontal face grain.
- These requirements assume a 100 PLF wall load and applied to the Joists. Additional support may be required for other loadings. See BC CALC® software.
- Contact Boise Cascade EWP Engineering for reinforcement requirements on Joist depths greater than 16".

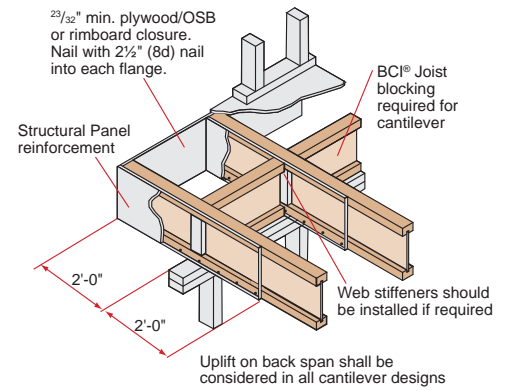

F05A

Non-Load Bearing Wall Cantilever Details

AJS®/BCI® Joists are intended only for applications that provide permanent protection from the weather.

F15A

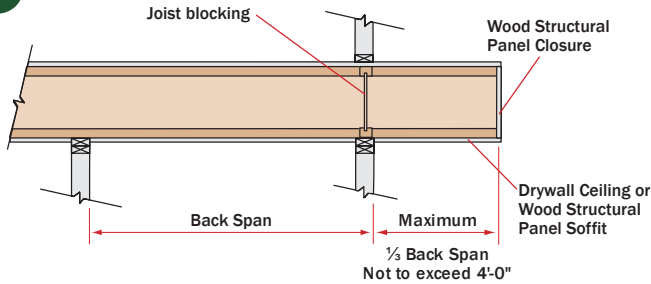

F15B

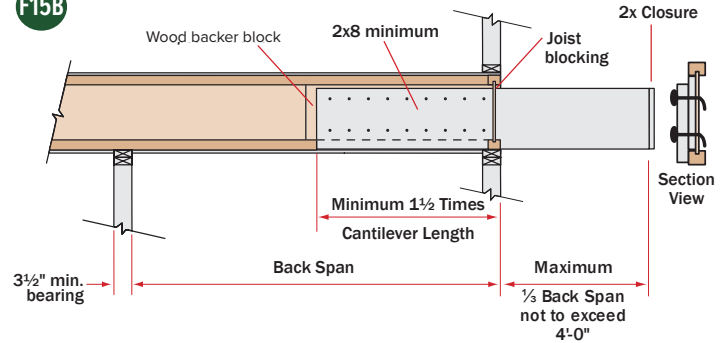

- These details apply to cantilevers with uniform loads only.
- It may be possible to exceed the limitations of these details by analyzing a specific application with the BC Calc® software.

Fasten the 2x8 minimum to the Joist by nailing through the backer block and joist web with 2 rows of 3" (10d) nails at 6" on center. Use $3\frac{1}{2}$ " (16d) nails with AJS® 25 and BCI® 90, 90s joists. Clinch all nails.

Brick Ledge Load Bearing Cantilever Details

F20A

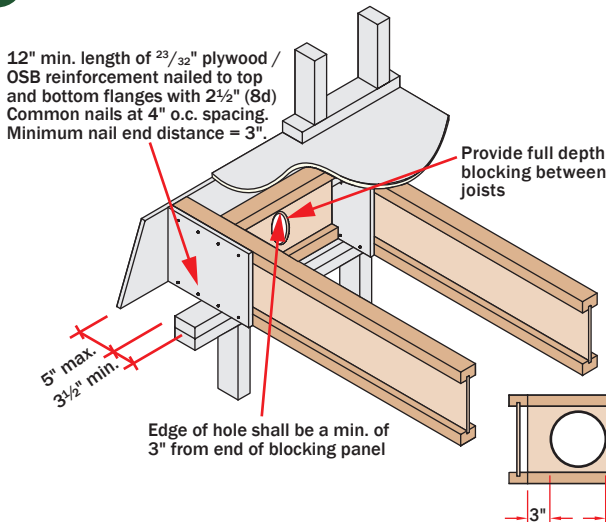

F20B

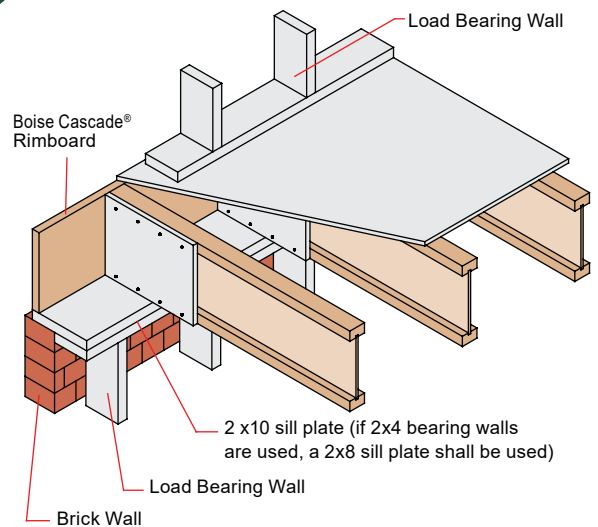

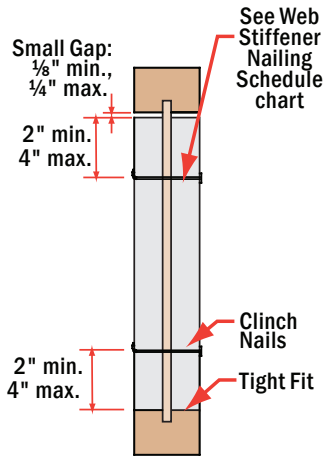

F16E

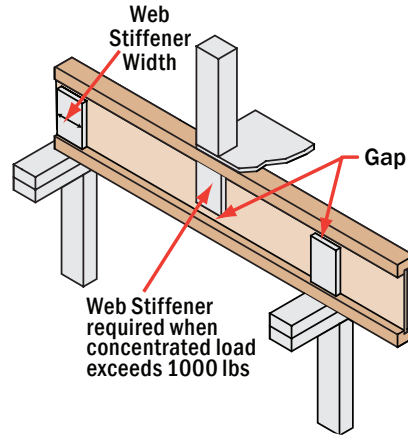

Structural Panel Web Stiffener			
Series	For Structural Capacity (Min. Thick)	Lateral Restraint in Hanger	Minimum Width
AJS® 140/20	1"	1"	2 ⁵ / ₁₆ "
AJS® 25	2x4 lumber (vertical)		
BCI® 4500s 1.8	5/8"	5/8"	2 ⁵ / ₁₆ "
BCI® 5000 1.8 BCI® 5000s 1.8	5/8"	3/4"	2 ⁵ / ₁₆ "
BCI® 6000 1.8 BCI® 6000s 1.8	3/4"	7/8"	2 ⁵ / ₁₆ "
BCI® 6500 1.8 BCI® 6500s 1.8	3/4"	1" or 1 1/8"	2 ⁵ / ₁₆ "
BCI® 60 2.0 BCI® 60s 2.0	3/4"	7/8"	2 ⁵ / ₁₆ "
BCI® 90 2.0 BCI® 90s 2.0	2x4 lumber (vertical)		

Web Stiffener Nailing Schedule			
ALLJOIST® Series	Joist Depth	Nailing	
AJS® 140 / 20 / 25	9 1/2" – 11 7/8"	3-3" (10d)	
	14" – 24"	5-3" (10d)	
BCI® Joist Series	Joist Depth	Bearing Location	
		End	Intermediate
4500s 1.8 5000 1.7 5000s 1.8	9 1/2"	2-2 1/2" (8d)	2-2 1/2" (8d)
	11 7/8"	2-2 1/2" (8d)	3-2 1/2" (8d)
	14"	2-2 1/2" (8d)	5-2 1/2" (8d)
6000 1.8 6000s 1.8	9 1/2"	2-2 1/2" (8d)	2-2 1/2" (8d)
	11 7/8"	2-2 1/2" (8d)	3-2 1/2" (8d)
	14"	2-2 1/2" (8d)	5-2 1/2" (8d)
	16"	2-2 1/2" (8d)	6-2 1/2" (8d)
6500 1.8 6500s 1.8	9 1/2"	2-2 1/2" (8d)	2-2 1/2" (8d)
	11 7/8"	2-2 1/2" (8d)	3-2 1/2" (8d)
	14"	2-2 1/2" (8d)	5-2 1/2" (8d)
	16"	2-2 1/2" (8d)	6-2 1/2" (8d)
60 2.0 60s 2.0	11 7/8"	2-2 1/2" (8d)	3-2 1/2" (8d)
	14"	2-2 1/2" (8d)	5-2 1/2" (8d)
	16"	2-2 1/2" (8d)	6-2 1/2" (8d)
90 2.0 90s 2.0	11 7/8"	3-3 1/2" (16d)	3-3 1/2" (16d)
	14"	5-3 1/2" (16d)	5-3 1/2" (16d)
	16"	6-3 1/2" (16d)	6-3 1/2" (16d)
	18"	7-3 1/2" (16d)	7-3 1/2" (16d)
	20"	8-3 1/2" (16d)	8-3 1/2" (16d)

NOTES:

- Web stiffeners are optional except as noted below:
- Stiffeners required at **ALL** bearing locations for all 18" to 24" deep joists.
- Web stiffeners are always required in hangers that do not extend up to support the top flange of the Joist. Web stiffeners may be required with certain sloped or skewed hangers or to achieve uplift values. Refer to the hanger manufacturer's installation requirements.
- Web stiffeners may be cut from structural rated wood panels, engineered rimboard or 2x lumber (Joist with flange of 3 1/2" width only).
- For Structural Capacity: Web stiffeners needed to increase the Joist's reaction capacity at a specific bearing location.
- Web stiffeners are always required in certain roof applications. See Roof Framing Details.
- Web stiffeners are always required under concentrated loads that exceed 1000 pounds. Install the web stiffeners snug to the top flange in this situation. Follow the nailing schedule for intermediate bearings.
- Web stiffeners may be used to increase allowable reaction values. See Factored Resistances Limit States Design (CANADA) on page 4 of the related specifier guide or the BC CALC® software.

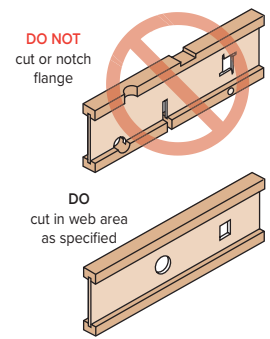
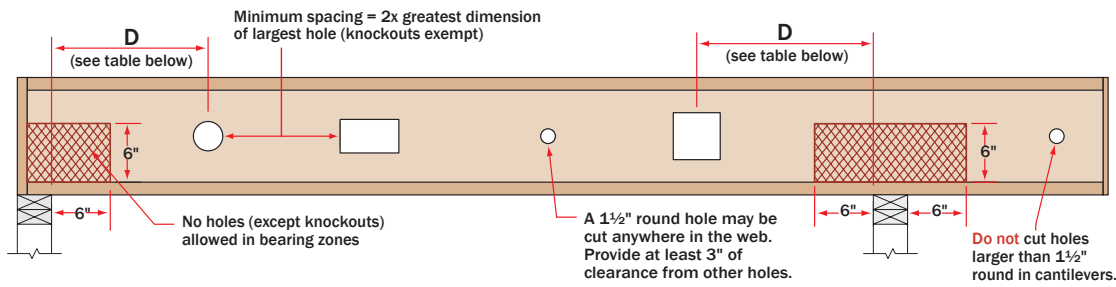

AJS®/BCI® Joists are manufactured with 1½" round perforated knockouts in the web at approximately 12" on center

Minimum distance from support, listed in table below, is required for all holes greater than 1½"

TABLE 1 AJS® ROUND HOLES - 9½" to 16"

Minimum distance from inside face of any support to the centerline of hole																JOIST DEPTH • HOLE SIZE [IN]			
Span [ft]	9½"				11½"				14"				16"						
	3"	6"	9"	12"	3"	6"	9"	12"	3"	6"	9"	12"	3"	6"	9"	12"			
8'	1'-0"	1'-6"	-	-	1'-0"	1'-0"	-	-	1'-0"	1'-0"	1'-0"	-	1'-0"	1'-0"	1'-0"	1'-0"			
10'	1'-0"	2'-6"	-	-	1'-0"	1'-0"	-	-	1'-0"	1'-0"	1'-0"	-	1'-0"	1'-0"	1'-0"	1'-0"			
12'	1'-0"	4'-0"	-	-	1'-0"	1'-0"	-	-	1'-0"	1'-0"	1'-0"	-	1'-0"	1'-0"	1'-0"	1'-6"			
14'	1'-0"	5'-0"	-	-	1'-0"	1'-0"	-	-	1'-0"	1'-0"	1'-6"	-	1'-0"	1'-0"	1'-0"	2'-6"			
16'	2'-0"	6'-6"	-	-	1'-0"	2'-0"	-	-	1'-0"	1'-0"	2'-6"	-	1'-0"	1'-0"	1'-0"	3'-6"			
18'	3'-0"	7'-6"	-	-	1'-0"	3'-6"	-	-	1'-0"	1'-0"	4'-0"	-	1'-0"	1'-0"	1'-0"	4'-6"			
20'	4'-0"	9'-0"	-	-	1'-0"	4'-6"	-	-	1'-0"	1'-0"	5'-0"	-	1'-0"	1'-0"	2'-0"	6'-0"			
22'	5'-0"	10'-0"	-	-	1'-6"	5'-6"	-	-	1'-0"	2'-6"	6'-0"	-	1'-0"	1'-0"	3'-0"	7'-0"			
24'	6'-6"	11'-6"	-	-	2'-6"	7'-0"	-	-	1'-0"	3'-6"	7'-6"	-	1'-0"	1'-0"	4'-0"	8'-0"			
26'	-	-	-	-	4'-0"	8'-0"	-	-	1'-0"	4'-6"	8'-6"	-	1'-0"	1'-6"	5'-6"	9'-6"			
28'	-	-	-	-	5'-0"	9'-0"	-	-	2'-0"	5'-6"	10'-0"	-	1'-0"	2'-6"	6'-6"	10'-6"			
30'	-	-	-	-	-	-	-	-	3'-0"	7'-0"	11'-0"	-	1'-0"	4'-0"	7'-6"	12'-0"			
32'	-	-	-	-	-	-	-	-	4'-0"	8'-0"	12'-6"	-	1'-6"	5'-0"	9'-0"	13'-0"			
34'	-	-	-	-	-	-	-	-	-	-	-	-	2'-6"	6'-0"	10'-0"	14'-6"			

NOTES:

- Hole may be positioned vertically anywhere in the web.
- Tables are for uniformly loaded maximum loads of 40 psf live loads and 15 psf dead loads on simple span application.
- AJS®/BCI® Joists are manufactured with 1½" round perforated knockouts in the web at approximately 12" on center.
- For other load conditions or hole sizes, contact your local distributor.
- It may be possible to exceed the limitations of those tables by analysing a specific situation with the BC CALC® Software.
- * = Holes may be acceptable, contact your local distributor.

TABLE 4 AJS® ROUND HOLES - 18" to 24"

Minimum distance from inside face of any support to the centerline of hole																JOIST DEPTH • HOLE SIZE [IN]			
Span [ft]	18"				20"				22"				24"						
	3"	6"	9"	12"	6"	9"	12"	15"	6"	9"	12"	15"	9"	12"	15"	18"			
8'	1'-0"	1'-0"	1'-0"	1'-0"	1'-0"	1'-0"	1'-0"	2'-0"	1'-0"	1'-0"	1'-0"	1'-0"	1'-0"	1'-0"	1'-0"	1'-0"			
10'	1'-0"	1'-0"	1'-0"	1'-0"	1'-0"	1'-0"	1'-0"	3'-6"	1'-0"	1'-0"	1'-0"	1'-0"	1'-0"	1'-0"	1'-0"	1'-0"			
12'	1'-0"	1'-0"	1'-0"	2'-6"	1'-0"	1'-0"	1'-0"	4'-6"	1'-0"	1'-0"	1'-0"	1'-0"	1'-0"	1'-0"	1'-0"	2'-0"			
14'	1'-0"	1'-0"	1'-0"	3'-6"	1'-0"	1'-0"	1'-0"	6'-0"	1'-0"	1'-0"	1'-0"	1'-0"	1'-6"	1'-0"	1'-0"	3'-6"			
16'	1'-0"	1'-0"	1'-0"	4'-6"	1'-0"	1'-0"	1'-0"	7'-0"	1'-0"	1'-0"	1'-0"	1'-0"	2'-6"	1'-0"	1'-0"	4'-6"			
18'	1'-0"	1'-0"	1'-0"	6'-0"	1'-0"	1'-0"	1'-6"	8'-6"	1'-0"	1'-0"	1'-0"	3'-6"	1'-0"	1'-0"	1'-0"	5'-6"			
20'	1'-0"	1'-0"	1'-0"	7'-0"	1'-0"	1'-0"	2'-6"	9'-6"	1'-0"	1'-0"	1'-0"	5'-0"	1'-0"	1'-0"	1'-0"	7'-0"			
22'	1'-0"	1'-0"	1'-6"	8'-6"	1'-0"	1'-0"	3'-6"	*	1'-0"	1'-0"	1'-0"	6'-0"	1'-0"	1'-0"	2'-0"	8'-0"			
24'	1'-0"	1'-0"	2'-6"	9'-6"	1'-0"	1'-0"	5'-0"	*	1'-0"	1'-0"	1'-0"	7'-0"	1'-0"	1'-0"	3'-6"	9'-6"			
26'	1'-0"	1'-0"	3'-6"	11'-0"	1'-0"	1'-0"	6'-0"	*	1'-0"	1'-0"	2'-6"	8'-6"	1'-0"	1'-0"	4'-6"	10'-6"			
28'	1'-0"	1'-0"	4'-6"	12'-0"	1'-0"	1'-0"	7'-0"	*	1'-0"	1'-0"	3'-6"	9'-6"	1'-0"	1'-0"	5'-6"	12'-0"			
30'	1'-0"	1'-0"	5'-6"	13'-6"	1'-0"	2'-0"	8'-6"	*	1'-0"	1'-0"	4'-6"	11'-0"	1'-0"	1'-0"	6'-6"	13'-0"			
32'	1'-0"	1'-0"	7'-0"	14'-6"	1'-0"	3'-0"	9'-6"	*	1'-0"	1'-0"	5'-6"	12'-0"	1'-0"	2'-6"	8'-0"	14'-6"			
34'	1'-0"	1'-6"	8'-0"	16'-0"	1'-0"	4'-6"	11'-0"	*	1'-0"	1'-0"	6'-6"	13'-6"	1'-0"	3'-6"	9'-0"	15'-6"			

TABLE 1 BCI® ROUND HOLES

Minimum distance from inside face of any support to centerline of hole																JOIST DEPTH • HOLE SIZE [IN]			
Span [ft]	9½"				11½"				14"				16"						
	3"	6"	9"	12"	3"	6"	9"	12"	3"	6"	9"	12"	3"	6"	9"	12"			
8'	1'-0"	1'-0"	-	-	1'-0"	1'-0"	-	-	1'-0"	1'-0"	1'-0"	-	1'-0"	1'-0"	1'-0"	1'-0"			
10'	1'-0"	1'-0"	-	-	1'-0"	1'-0"	-	-	1'-0"	1'-0"	1'-0"	-	1'-0"	1'-0"	1'-0"	1'-0"			
12'	1'-0"	2'-0"	-	-	1'-0"	1'-0"	-	-	1'-0"	1'-0"	1'-0"	-	1'-0"	1'-0"	1'-0"	1'-0"			
14'	1'-0"	3'-0"	-	-	1'-0"	1'-0"	-	-	1'-0"	1'-0"	1'-0"	-	1'-0"	1'-0"	1'-0"	2'-0"			
16'	1'-0"	4'-0"	-	-	1'-0"	1'-0"	-	-	1'-0"	1'-0"	2'-0"	-	1'-0"	1'-0"	1'-0"	3'-0"			
18'	1'-0"	5'-0"	-	-	1'-0"	2'-0"	-	-	1'-0"	1'-0"	3'-0"	-	1'-0"	1'-0"	1'-0"	4'-0"			
20'	1'-6"	6'-6"	-	-	1'-0"	3'-0"	-	-	1'-0"	1'-0"	4'-0"	-	1'-0"	1'-0"	2'-0"	5'-0"			
22'	2'-6"	7'-6"	-	-	1'-0"	4'-0"	-	-	1'-0"	1'-6"	5'-6"	-	1'-0"	1'-0"	3'-0"	6'-6"			
24'	3'-6"	9'-0"	-	-	1'-6"	5'-6"	-	-	1'-0"	2'-6"	6'-6"	-	1'-0"	1'-0"	4'-0"	7'-6"			
26'	-	-	-	-	2'-6"	6'-6"	-	-	1'-0"	4'-0"	7'-6"	-	1'-0"	2'-0"	5'-0"	9'-0"			
28'	-	-	-	-	3'-6"	7'-6"	-	-	1'-6"	5'-0"	9'-0"	-	1'-0"	3'-0"	6'-6"	10'-0"			
30'	-	-	-	-	-	-	-	-	2'-6"	6'-0"	10'-0"	-	1'-0"	4'-0"	7'-6"	11'-6"			
32'	-	-	-	-	-	-	-	-	3'-6"	7'-0"	11'-6"	-	2'-0"	5'-0"	8'-6"	12'-6"			
34'	-	-	-	-	-	-	-	-	-	-	-	-	3'-0"	6'-0"	10'-0"	14'-0"			

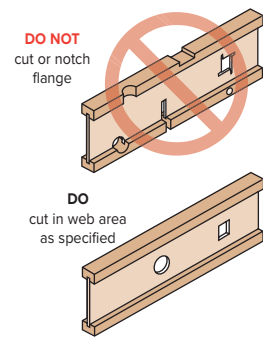
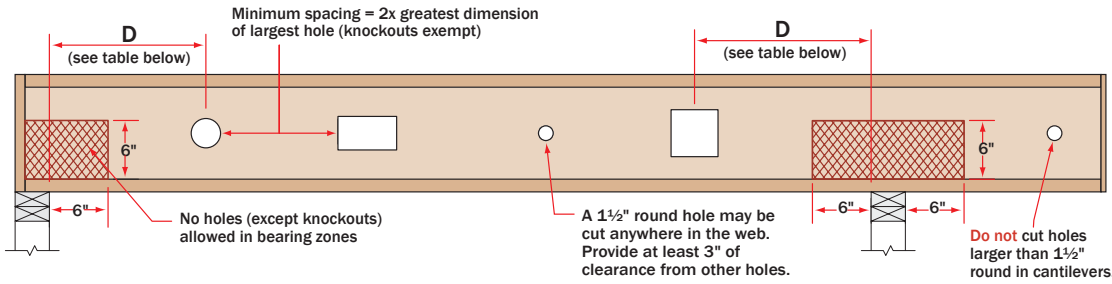

AJS® / BCI® Joists are manufactured with 1½" round perforated knockouts in the web at approximately 12" on center

Minimum distance from support, listed in table below, is required for all holes greater than 1½"

TABLE 3 **RECTANGULAR HOLES**

Minimum distance from inside face of any support to the centerline of hole		JOIST DEPTH • HOLE SIZE [IN]														
Span [ft]	9½"				11⅝"				14"				16"			
	5"x8"	5"x10"	5"x12"	5"x14"	7"x10"	7"x12"	7"x14"	7"x16"	10"x12"	10"x14"	10"x16"	10"x18"	10"x16"	10"x18"	12"x14"	12"x16"
8'	1'-6"	2'-0"	2'-0"	2'-6"	1'-0"	1'-6"	2'-0"	2'-6"	1'-6"	2'-6"	3'-0"	*	1'-6"	2'-6"	2'-0"	3'-0"
10'	2'-6"	3'-0"	3'-6"	4'-0"	2'-0"	2'-6"	3'-6"	4'-0"	3'-0"	3'-6"	4'-6"	*	3'-0"	4'-0"	3'-0"	4'-0"
12'	3'-6"	4'-0"	4'-6"	5'-0"	3'-6"	4'-0"	4'-6"	5'-0"	4'-0"	4'-6"	5'-6"	*	4'-0"	5'-0"	4'-6"	5'-6"
14'	5'-0"	5'-6"	6'-0"	6'-6"	4'-6"	5'-0"	6'-0"	6'-6"	5'-0"	6'-0"	*	*	5'-6"	6'-6"	5'-6"	6'-6"
16'	6'-0"	6'-6"	7'-0"	7'-6"	5'-6"	6'-6"	7'-0"	*	6'-6"	7'-6"	*	*	6'-6"	7'-6"	7'-0"	*
18'	7'-6"	8'-0"	8'-6"	*	7'-0"	7'-6"	8'-6"	*	7'-6"	8'-6"	*	*	8'-0"	*	8'-0"	*
20'	8'-6"	9'-0"	9'-6"	*	8'-0"	9'-0"	9'-6"	*	9'-0"	*	*	*	9'-0"	*	9'-6"	*
22'	10'-0"	10'-6"	*	*	9'-6"	10'-0"	*	*	10'-6"	*	*	*	10'-6"	*	*	*
24'	11'-0"	*	*	*	10'-6"	11'-6"	*	*	11'-6"	*	*	*	11'-6"	*	*	*
26'	-	-	-	-	12'-0"	*	*	*	*	*	*	*	*	*	*	*
28'	-	-	-	-	13'-6"	*	*	*	*	*	*	*	*	*	*	*
30'	-	-	-	-	-	-	-	-	*	*	*	*	*	*	*	*
32'	-	-	-	-	-	-	-	-	*	*	*	*	*	*	*	*
34'	-	-	-	-	-	-	-	-	-	-	-	-	*	*	*	*

NOTES:

- Hole may be positioned vertically anywhere in the web.
- Tables are for uniformly loaded maximum loads of 40 psf live loads and 15 psf dead loads on simple span application.
- AJS®/BCI® Joists are manufactured with 1½" round perforated knockouts in the web at approximately 12" on center.
- For other load conditions or hole sizes, contact your local distributor.
- It may be possible to exceed the limitations of those tables by analysing a specific situation with the BC CALC® Software.
- * = Holes may be acceptable, contact your local distributor.

TABLE 6 **RECTANGULAR HOLES**

Minimum distance from inside face of any support to the centerline of hole		JOIST DEPTH • HOLE SIZE [IN]														
Span [ft]	18"				20"				22"				24"			
	10"x18"	12"x14"	12"x16"	12"x18"	12"x16"	12"x18"	14"x16"	14"x18"	12"x18"	14"x16"	14"x18"	16"x18"	14"x18"	14"x20"	16"x18"	16"x20"
8'	1'-6"	1'-0"	1'-6"	3'-0"	1'-0"	1'-6"	1'-6"	3'-0"	1'-0"	1'-0"	2'-0"	3'-0"	1'-0"	2'-0"	2'-0"	3'-6"
10'	2'-6"	1'-6"	3'-0"	4'-0"	1'-6"	3'-6"	3'-0"	4'-6"	2'-0"	1'-6"	3'-0"	4'-6"	2'-0"	3'-6"	3'-0"	*
12'	4'-0"	3'-0"	4'-0"	5'-6"	2'-6"	4'-0"	4'-0"	5'-6"	3'-0"	3'-0"	4'-0"	5'-6"	3'-0"	4'-6"	4'-6"	*
14'	5'-0"	4'-0"	5'-6"	6'-6"	4'-0"	5'-6"	5'-6"	*	4'-0"	4'-0"	5'-6"	*	4'-0"	6'-0"	5'-6"	*
16'	6'-6"	5'-6"	6'-6"	*	5'-0"	6'-6"	6'-6"	*	5'-6"	5'-0"	6'-6"	*	5'-6"	7'-0"	7'-0"	*
18'	7'-6"	6'-6"	8'-0"	*	6'-6"	8'-0"	8'-0"	*	6'-6"	6'-6"	8'-0"	*	6'-6"	8'-6"	8'-0"	*
20'	9'-0"	7'-6"	9'-0"	*	7'-6"	9'-0"	9'-0"	*	7'-6"	7'-6"	9'-0"	*	8'-0"	9'-6"	9'-6"	*
22'	10'-0"	9'-0"	10'-6"	*	9'-0"	10'-6"	10'-6"	*	9'-0"	9'-0"	10'-6"	*	9'-0"	*	10'-6"	*
24'	11'-6"	10'-0"	11'-6"	*	10'-6"	11'-6"	11'-6"	*	10'-6"	10'-0"	*	*	10'-6"	*	*	*
26'	12'-6"	11'-6"	*	*	11'-6"	*	*	*	11'-6"	11'-6"	*	*	11'-6"	*	*	*
28'	*	12'-6"	*	*	12'-6"	*	*	*	13'-0"	12'-6"	*	*	13'-0"	*	*	*
30'	*	14'-0"	*	*	14'-0"	*	*	*	14'-0"	14'-0"	*	*	14'-6"	*	*	*
32'	*	15'-6"	*	*	15'-0"	*	*	*	15'-6"	15'-6"	*	*	15'-6"	*	*	*
34'	*	16'-6"	*	*	16'-6"	*	*	*	16'-6"	16'-6"	*	*	*	*	*	*

TABLE 3 **RECTANGULAR HOLES**

Minimum distance from inside face of any support to the centerline of hole		JOIST DEPTH • HOLE SIZE [IN]														
Span [ft]	9½"				11⅝"				14"				16"			
	5"x8"	5"x10"	5"x12"	5"x14"	7"x10"	7"x12"	7"x14"	7"x16"	10"x12"	10"x14"	10"x16"	10"x18"	10"x16"	10"x18"	12"x14"	12"x16"
8'	1'-6"	2'-0"	2'-0"	2'-6"	1'-0"	1'-6"	2'-0"	2'-6"	1'-6"	2'-6"	3'-0"	*	1'-6"	2'-6"	2'-0"	3'-0"
10'	2'-6"	3'-0"	3'-6"	4'-0"	2'-0"	2'-6"	3'-6"	4'-0"	3'-0"	3'-6"	4'-6"	*	3'-0"	4'-0"	3'-0"	4'-0"
12'	3'-6"	4'-0"	4'-6"	5'-0"	3'-6"	4'-0"	4'-6"	5'-0"	4'-0"	4'-6"	5'-6"	*	4'-0"	5'-0"	4'-6"	5'-6"
14'	5'-0"	5'-6"	6'-0"	6'-6"	4'-6"	5'-0"	6'-0"	6'-6"	5'-0"	6'-0"	*	*	5'-6"	6'-6"	5'-6"	6'-6"
16'	6'-0"	6'-6"	7'-0"	7'-6"	5'-6"	6'-0"	7'-0"	*	6'-6"	7'-6"	*	*	6'-6"	7'-6"	7'-0"	*
18'	7'-6"	8'-0"	8'-6"	*	7'-0"	7'-6"	8'-6"	*	7'-6"	8'-6"	*	*	8'-0"	*	8'-0"	*
20'	8'-6"	9'-0"	9'-6"	*	8'-0"	9'-0"	9'-6"	*	9'-0"	*	*	*	9'-0"	*	9'-6"	*
22'	10'-0"	10'-6"	*	*	9'-6"	10'-0"	*	*	10'-6"	*	*	*	10'-6"	*	*	*
24'	11'-0"	*	*	*	10'-6"	11'-6"	*	*	11'-6"	*	*	*	11'-6"	*	*	*
26'	-	-	-	-	12'-0"	*	*	*	*	*	*	*	*	*	*	*
28'	-	-	-	-	13'-6"	*	*	*	*	*	*	*	*	*	*	*
30'	-	-	-	-	-	-	-	-	*	*	*	*	*	*	*	*
32'	-	-	-	-	-	-	-	-	*	*	*	*	*	*	*	*
34'	-	-	-	-	-	-	-	-	-	-	-	-	*	*	*	*

Nail Size	Nailing Parallel to Glue Lines (Narrow Face) ^{(1) (2)}											Nailing Perpendicular to Glue Lines (Wide Face)	
	Eastern Products					Western Products						All Products	
	Versa-Lam® 1¾"		Versa-Lam® 3½" & Wider			Versa-Lam® 1⅝"		Versa-Lam® 1¾"		Versa-Lam® 3½" & Wider			
	O.C. [inches]	End [inches]	O.C. [inches]	End [inches]	O.C. [inches]	End [inches]	O.C. [inches]	End [inches]	O.C. [inches]	End [inches]	O.C. [inches]	End [inches]	
2½" (8d) Box	4	4	4	4	3	1½	2	1	2	½	2	½	
2½" (8d) Common	4	4	4	4	3	2	3	2	2	1	2	1	
3" (10d) & 3¼" (12d) Box	4	4	4	4	3	2	3	2	2	1	2	1	
3½" (16d) Box	4	4	4	4	3	2	3	2	2	1	2	1	
3" (10d) & 3¼" (12d) common	4	4	4	4	4	3	4	3	2	2	2	2	
3½" (16d) Sinker	4	4	4	4	4	3	4	3	2	2	2	2	
3½" (16d) Common	8	8	8	8	6	4	6	3	2	2	2	2	

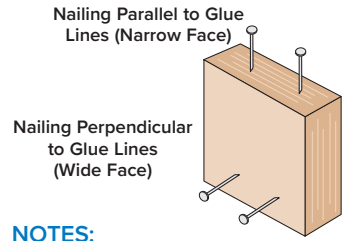

NOTES:

- For 1¾" thickness and greater, 2 rows of nails (such as for a metal strap) are allowed (use ½" minimum offset between rows and stagger nails).
- Offset and stagger nail rows from floor sheathing and wall sole plate.

Versa-Stud® & Versa-Lam® Column Details

Multiple Ply Stud Connections

Staggered rows

9"

NOTE:
The number of rows of fasteners should be as follows:

Stud/column depth	Rows of fasteners (staggered)
3½"	1
5½"	2
7¼"	2
9¼"	3
9½"	3
11¼"	3
11⅞"	3
14"	4

Thickness (in)	Number of plies	Fastener type	Fastener diameter (in)	Fastener length (in)	Min. end distance (in)	Min. edge distance (in)
1¾"	2	Common Nail 3½" (16d)	0.162	3½	4.0	2.0
		SDW 22338	0.220	3⅝		
		3⅝" TrussLok	0.228	3⅝		
		SDS ¼ x 3½	0.250	3½		
	3	Common Nail 5" (40d)	0.225	5		
		5" TrussLok	0.228	5		
		SDW 22500	0.220	5		
		½" dia. Bolts	0.500	7		
	4	SDW 22634	0.220	6¾		
		6¾" TrussLok	0.228	6¾		
		SDS ¼ x 6 (on both sides)	0.250	6		

Column to Top Plate

Double top plate

Framing angles for lateral support

Versa-Lam® Column

Trimmer Stud(s)

Column to Bottom Plate

Versa-Lam® Column

Sole plate

Rimboard

Sill Plate

Blocking panel, per design professional of record

Squash blocks required if column/trimmers do not extend to sill plate. Use same connections as column above.

Header to Column

Versa-Lam® Column

Plate size to equal wall thickness

Versa-Lam® Header

Rotated Versa-Lam® Header

Trimmer(s) for vertical support

Versa-Stud® Allowable Holes and Notches

Prescriptive Provisions

Hole Edge Distance
Min. of ⅝"

Max. Hole Diameter
1½" x 3½" = 1⅜"
1½" x 5½" = 2⅞"
1½" x 7¼" & deeper = 2⅞"
(1) max. dia hole allowed per stud, located at any location along stud length. DO NOT cut hole and notch at same location.

Max. Notch Depth
1½" x 3½" = 7⁄8"
1½" x 5½" = 1⅜"
1½" x 7¼" & deeper = 1⅜"

Max. Notch Height
= 3"

(1) notch allowed per stud. DO NOT cut notch and hole at same location.

Engineered Design Provisions

Allowable Hole Zone

- Middle ⅓rd of stud
- No holes within 8" of top or bottom

Max. Hole Diameter
1½" x 3½" = ¾"
1½" x 5½" = 1"
1½" x 7¼" & deeper = 1¼"

8"

1⁄3rd stud width

Middle ⅓rd stud width

Notes:

- DO NOT drill more than 3 holes in any 4-foot-long section of stud.
- The vertical distance between adjacent holes must be at least 2 times the size of the larger hole
- Holes no greater than ¾" dia may be cut in the hole zone shown in Versa-Lam® columns.
- For notches and larger holes, contact Boise Cascade EWP Engineering.

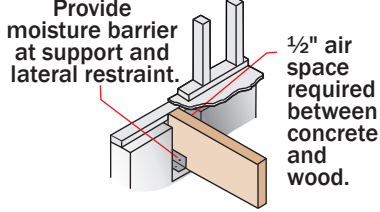
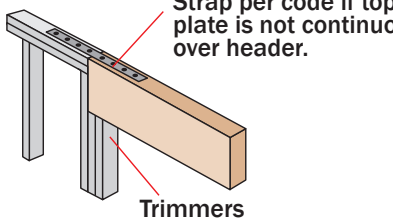
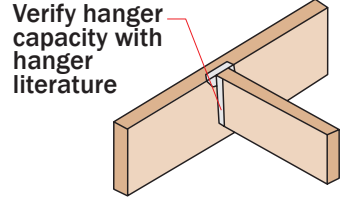
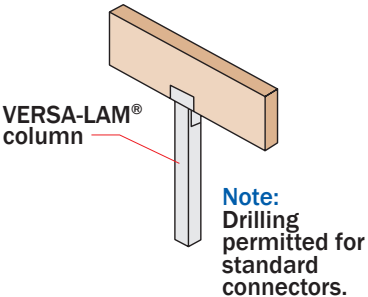
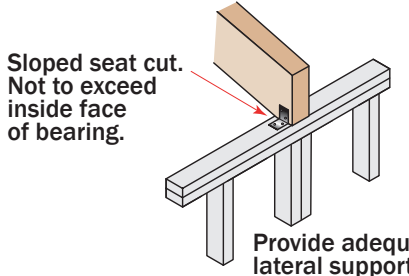
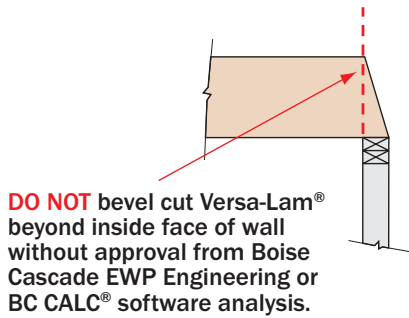
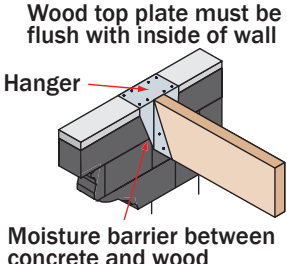
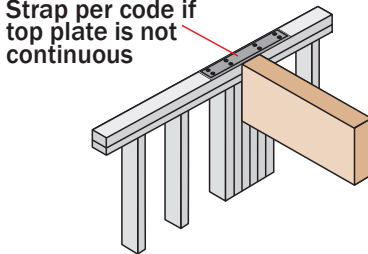
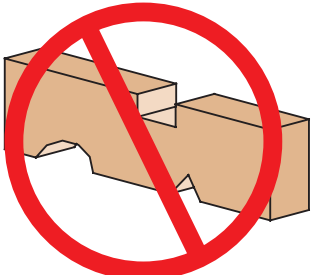
<p>B01 Bearing at concrete/masonry walls</p> 	<p>B02 Bearing for door or window header</p> 	<p>B03 Beam to beam connector</p> 
<p>B04 Bearing at column</p> 	<p>B06 Slope seat cut</p> 	<p>B07 Bevel cut</p> 
<p>B08 Beam to concrete/masonry walls</p> 	<p>B09 Bearing framing into wall</p> 	<p>DO NOT drill, notch, cut or alter Versa-Lam® beams</p> 

NOTES

- Minimum of 1/2" air space between beam and wall pocket or adequate barrier must be provided between beam and concrete/masonry.
- Adequate bearing shall be provided. If not shown on plans, please refer to load tables in your region's Specifier Guide.
- Versa-Lam® beams are intended for interior applications only and should be kept as dry as possible during construction.
- Continuous lateral support of top and bottom of beam shall be provided (side or top bearing framing).

Allowable Holes in Versa-Lam® Beams

NOTES

1. Square and rectangular holes are not permitted.
2. Round holes may be drilled or cut with a hole saw anywhere within the shaded area of the beam.
3. The horizontal distance between adjacent holes must be at least two times the size of the larger hole.
4. Do not drill more than three access holes in any four foot long section of beam.
5. The maximum round hole diameter permitted is:

Beam Depth	Max. Hole Diameter
5 1/2"	3/4"
7 1/4"	1"
Greater than 7 1/4"	2"

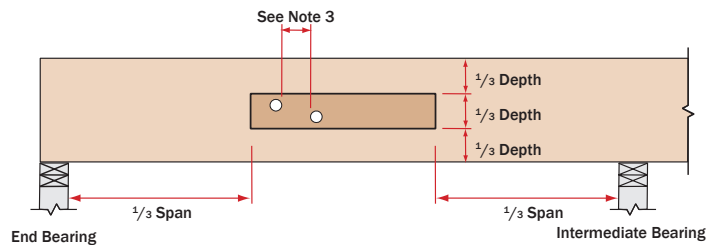

6. These limitations apply to holes drilled for plumbing or wiring access only. The size and location of holes drilled for fasteners are under the regulations of the CSA O86-14 Engineering Design in Wood.
7. Beams deflect under load. Size holes to provide clearance where required.
8. This hole chart is valid for beams supporting uniform load only. For beams supporting concentrated loads or for beams with larger holes, contact Boise Cascade EWP Engineering.

Rows	Depth Range	Spacing				
			3 1/2" (2 plies)	5 1/4" (3 plies)	5 1/4" (2 plies)	7" (3 plies)
Maximum Factored Uniform Load (PLF) Applied to Either Outside Member						
3.5" Common Wire Nails (16d)						
2	7 1/4" to 18"	24"	434	325	325	289
		12"	867	650	650	578
		6"	1734	1301	1301	1156
3	11 7/8" to 24"	24"	650	488	488	434
		12"	1301	976	976	867
		6"	2602	1951	1951	1734
4	14" to 24"	24"	867	650	650	578
		12"	1734	1301	1301	1156
		6"	3469	2602	2602	2312

Rows	Depth Range	Spacing				
			3 1/2" (2 plies)	5 1/4" (3 plies)	7" (2 plies)	7" (4 plies)
Maximum Factored Uniform Load (PLF) Applied to Either Outside Member						
SDW22338 SDW22500 SDW22634 SDW22634						
2	7 1/4" to 18"	24"	680	623	1140	553
		12"	1360	1245	2280	1107
		6"	2720	2490	4560	2213
3	11 7/8" to 24"	24"	1020	934	1710	830
		12"	2040	1868	3420	1660
		6"	4080	3735	6840	3320
4	14" to 24"	24"	1360	1245	2280	1107
		12"	2720	2490	4560	2213
		6"	5440	4980	9120	4427

Rows	Depth Range	Spacing				
			3 1/2" (2 plies)	5 1/4" (3 plies)	7" (2 plies)	7" (4 plies)
Maximum Factored Uniform Load (PLF) Applied to Either Outside Member						
SDS 1/4"x3.5" SDS 1/4"x3.5" SDS 1/4"x6" SDS 1/4"x6"						
2	7 1/4" to 18"	24"	610	458	610	520
		12"	1220	915	1220	1040
		6"	2440	1830	2440	2080
3	11 7/8" to 24"	24"	915	686	915	780
		12"	1830	1373	1830	1560
		6"	3660	2745	3660	3120
4	14" to 24"	24"	1220	915	1220	1040
		12"	2440	1830	2440	2080
		6"	4880	3660	4880	4160

Rows	Depth Range	Spacing				
			3 1/2" (2 plies)	5 1/4" (3 plies)	7" (2 plies)	7" (4 plies)
Maximum Factored Uniform Load (PLF) Applied to Either Outside Member						
3/8" TrussLok 5" TrussLok 6 3/4" TrussLok 6 3/4" TrussLok						
2	7 1/4" to 18"	24"	864	675	849	600
		12"	1,728	1,350	1,698	1,200
		6"	3,456	2,700	3,396	2,400
3	11 7/8" to 24"	24"	1,296	1,013	1,274	900
		12"	2,592	2,025	2,547	1,800
		6"	5,184	4,050	5,094	3,600
4	14" to 24"	24"	1,728	1,350	1,698	1,200
		12"	3,456	2,700	3,396	2,400
		6"	6,912	5,400	6,792	4,800

Rows	Depth Range	Spacing						
			3 1/2" (2 plies)	5 1/4" (3 plies)	5 1/4" (2 plies)	7" (3 plies)	7" (2 plies)	7" (4 plies)
Maximum Factored Uniform Load (PLF) Applied to Either Outside Member								
1/2" Bolts								
2	7 1/4" to 11 7/8"	12"	1560	1170	1755	1560	3120	1040
		6"	3120	2340	3510	3120	6240	2080
3	11 7/8" to 24"	12"	2340	1755	2632	2340	4680	1560
		6"	4680	3510	5265	4680	9360	3120

NOTES

- Design values apply to common bolts that conform to ASTM A307 Grades A&B, SAE J429 Grades 2 or higher. A washer not less than a standard cut washer shall be between the wood and the bolt head and between the wood and the nut. The minimum edge distance for SDS/TrussLok screws and bolts shall be 2". The minimum end distance for SDS/TrussLok screws and bolts shall be 4", except for SDW screws where the end distance should not be less than 6". Bolt holes shall not be greater than 1/16 of the bolt diameter.
- When 3 1/4" sinker nails (16d) are used, multiply the maximum factored uniform load for the 3.5" common wire nails by 0.87 factor.
- When 3 1/4" pneumatic gun nails 0.122" diameter (10d) are used, multiply the maximum factored uniform load for the 3.5" common wire nails by 0.61 factor.
- The nail schedules shown apply to both sides of a 3-member beam.
- 4-ply beams must be loaded from both sides. Lesser side shall be no less than 25% of the opposite side.
- Beams wider than 7" must be designed by the professional engineer of record.
- An equivalent specific gravity of 0.5 may be used when designing specific connections with Versa-Lam. Connection design is based on CSA O86-14.
- Refer to current technical literature from FastenMaster TrussLok and Simpson Strong-Tie to confirm information herein has not been superseded.
- Other fasteners may also be used to connect multiple Versa-Lam beams. Contact Boise Cascade EWP Engineering for further information.

WARNING

THE FOLLOWING USES ARE NOT ALLOWED

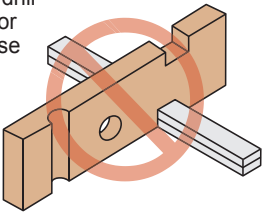
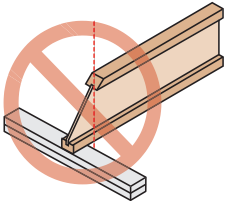
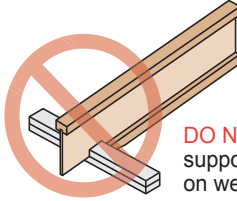
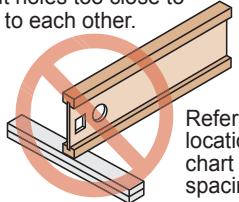
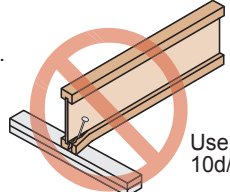
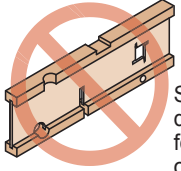
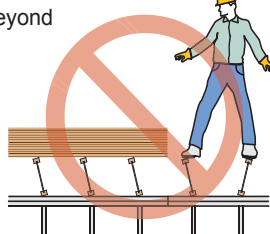
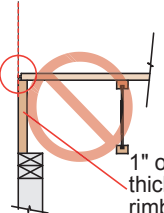
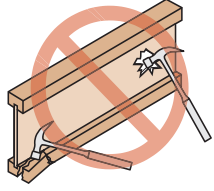
<p>DO NOT notch or drill beams without prior approval from Boise Cascade EWP Engineering.</p> 	<p>DO NOT cut beyond inside edge of bearing.</p> 	<p>DO NOT support joist on web.</p> 
<p>DO NOT cut holes too close to supports or to each other.</p>  <p>Refer to hole location and sizing chart for size and spacing.</p>	<p>DO NOT nail closer than 1 1/2" from end of joist.</p> <p>DO NOT use 16d common nails.</p>  <p>Use 8d nails or 10d/16d box nails.</p>	<p>DO NOT cut or notch flange.</p>  <p>See roof and floor details, this sheet, for allowed cutting of flange.</p>
<p>DO NOT walk on joist until proper bracing is in place.</p> <p>DO NOT load joist beyond design capacity.</p> <p>DO NOT stack building materials on unbraced joists.</p> 	<p>DO NOT install tongue of floor sheathing flush with either 1" or 1 1/16" thick Boise Cascade rimboard (tongue OK with 1 1/8" and thicker Boise Cascade rimboard).</p>  <p>1" or 1 1/16" thick Boise rimboard</p> <p>T&G Floor Sheathing</p> <p>Trim tongue of 1 1/8" sheathing regardless of rimboard thickness.</p> <p>Trim tongue flush with rim.</p>	<p>DO NOT hammer on web unless removing knockout holes.</p>  <p>DO NOT hammer on flange.</p>

SAFETY WARNING

DO NOT ALLOW WORKERS ON BCI® JOISTS UNTIL ALL HANGERS, BCI® RIM JOISTS, RIM BOARDS, BCI® BLOCKING PANELS, X-BRACING AND TEMPORARY 1x4 STRUT LINES ARE INSTALLED AS SPECIFIED BELOW. SERIOUS ACCIDENTS CAN RESULT FROM INSUFFICIENT ATTENTION TO PROPER BRACING DURING CONSTRUCTION. ACCIDENTS CAN BE AVOIDED UNDER NORMAL CONDITIONS BY FOLLOWING THESE GUIDELINES:

- Build a braced end wall at the end of the bay, or permanently install the first eight feet of BCI® Joists and the first course of sheathing. As an alternate, temporary sheathing may be nailed to the first four feet of BCI® Joists at the end of the bay.
- All hangers, BCI® rim joists, rim boards, BCI® blocking panels, and x-bracing must be completely installed and properly nailed as each BCI® Joist is set.
- Install temporary 1x4 strut lines at no more than eight feet on center as additional BCI® Joists are set. Nail the strut lines to the sheathed area, or braced end wall, and to each BCI® Joist with two 8d nails.
- The ends of cantilevers must be temporarily secured by strut lines on both the top and bottom flanges.

PRODUCT HANDLING TO AND AT JOB SITES

There are some differences between engineered wood products and traditional lumber products in terms of product handling: Avoid handling and storing BCI® joists in the flat direction. Versa-Lam® is heavier than solid sawn timber. Please consider these differences when transporting and handling engineered wood products.

- Straighten the BCI® Joists to within 1/2 inch of true alignment before attaching strut lines and sheathing.
- Remove the temporary strut lines only as required to install the permanent sheathing.
- Failure to install temporary bracing may result in sideways buckling or roll-over under light construction loads.
- Do not stack construction materials (sheathing, drywall, etc.) in the middle of BCI® Joist spans, contact Boise Cascade EWP Engineering for proper storage and shoring information.

Lifetime Guaranteed Quality and Performance

Boise Cascade warrants its BCI® Joist, Versa-Lam®, and ALLJOIST® products to comply with our specifications, to be free from defects in material and workmanship, and to meet or exceed our performance specifications for the normal and expected life of the structure when correctly stored, installed and used according to our Installation Guide.

Boise Cascade has not evaluated the effects of any pressure or topical applications or treatments on its BCI® Joist, Versa-Lam®, and ALLJOIST® products.

For information about Boise Cascade's engineered wood products, including sales terms and conditions, warranties and disclaimers, [visit our website at www.BC.com/ewp](http://www.BC.com/ewp)

To locate your nearest Boise Cascade Engineered Wood Products distributor, call **1-800-964-6999**